

User manual

LD111-M7-R-...

LD112-M7-R-...

Description

This manual describes the LD110 battery display series. The purpose of this system is to display linear or angular displacements on industrial machines and on automation systems. The measurement system includes a battery powered LCD display, magnetic tape and a magnetic sensor. As the sensor is moved along the magnetic tape, it detects the displacement which is shown on the display. The flexibility of the tape allows it to be used for both linear and angular applications.

Chapters

- 1 Safety summary
- 2 Identification
- 3 Installation
- 4 Mounting recommendations
- 5 Setup
- 6 Dimensional drawings and cut-out

1 - Safety summary

We strongly recommend carefully reading this user manual and following the installation guidelines:

- Sensor head should be installed as close as possible to the display.
- Avoid running the sensor cable near high voltage power cables (e.g. drive cables).
- Avoid mounting sensor head near capacitive or inductive noise sources such as relays, motors, and switching power supplies.

2 - Identification

The display and sensor can be identified by the label's data (ordering code, serial number). This information is listed in the delivery document. For technical features please refer to the product catalogue.

3 - Installation

Install the device according to the protection level provided. Protect the system against knocks, friction, solvents and respect the environmental characteristics of the product.

4 - Mounting recommendations

4.1 Display

Push the display into the cut-out without panel clips. Install panel clips on the display's housing and screw until fixed and stable.

Power supply by 2 1.5V commercial batteries type AAA (or AM4 / MICRO / LR03 / MN2400 / SP/HP16).

4.2 Magnetic tape

See manual supplied with the magnetic tape.

4.3 Sensor mounting

4.3.1 Sensor SM25-R (rectangular)

Sensor can be fixed by means of two M3 screws over the buttonholes. Make sure that the gap between sensor and tape is in respect with (fig. 1) along the total measuring length. Avoid contact between the parts. You can check planarity and parallelism between sensor and magnetic tape using a feeler gauge.

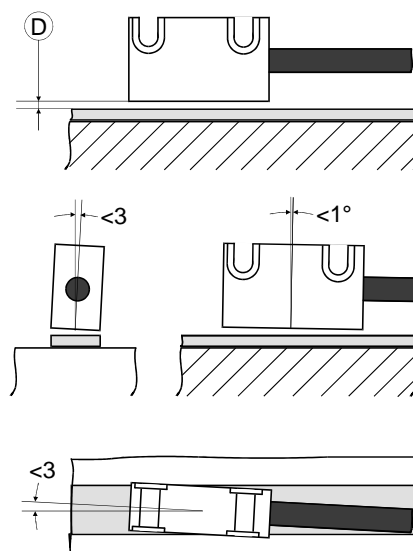
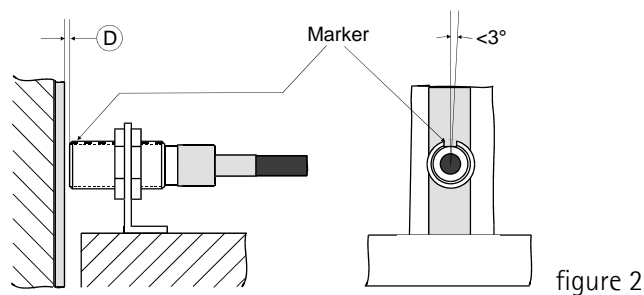

figure 1

D = 0,1 mm - 1,0 mm

4.3.2 Sensor SM25-C (circular)

The sensor can be fixed in a corresponding mounting hole by means of the two nuts. Make sure that the gap between sensor and tape is in respect with (fig. 2) along the total measuring length. **Observe the correct alignment of the marker on the tape.** Avoid contact between the parts. You can check planarity and parallelism between sensor and magnetic tape using a feeler gauge.



D = 0,1 mm - 1,0 mm

figure 2

5 - Setup

5.1 Key's function

- ↑ : UP (select value)
- ← : Shift links (select digit)
- * : Save (save data)
- P : Program (programming/change parameter)

5.2 Key combinations / Quick functions

5.2.1 Set datum (reference)

Push * key for 3 s to set actual value to datum value. Datum value is result of rEF + OFSt1 + OFStx (where OFStx is the actually set Offset value). This function is enabled only if "F_rSt" parameter is set "yES".

5.2.2 Incremental measurement

Push P and * key simultaneously to switch from absolute measurement to incremental. Zero setting in incremental modes (see 5.2.1) does not change absolute value in the background. The function is enabled only if "F_rEL" parameter is set "yES".

5.2.3 Mm/inch display modes

Mm/inch display modus can be changed by pushing ← key for 3 s. The function is enabled only if "F_mml" parameter is set "yES".

5.2.4 Offset value modification

Push P and ← keys simultaneously to display 1. Offset value (OFSt1). Use ← and ↑ keys to change value and save with * key. Further Offset values OFSt2 and OFSt3 can be changed only in setup menu.

Offset function is enable if "F_oFS" parameter is set "yES".

← key allows to scroll OFSt1, OFSt2 and OFSt3 values.

OFSt1 = actual value + OFSt1 + rEF

OFSt2 = actual value + OFSt1 + OFSt2 + rEF

OFSt3 = actual value + OFSt1 + OFSt3 + rEF

5.2.4.1 Fractional offset display

The fractional inch display mode allows to set offset values (OFSt) in the following way:

- 1st digit blinking → increases $\frac{1}{64}$ " pushing ↑ key.
- 2nd digit blinking → increases $\frac{1}{32}$ " pushing ↑ key.
- 3rd digit blinking → increases $\frac{1}{16}$ " pushing ↑ key.
- 4th digit blinking → increases $\frac{1}{8}$ " pushing ↑ key.
- 5th digit blinking → increases 1" pushing ↑ key.
- 6th digit blinking → increases 10" pushing ↑ key.

5.2.5 Datum modification

Push simultaneously P and ↑ keys to display datum value rEF. Use ← and ↑ keys to change value and save with * key.

This function is enabled only if "F_rEF" parameter is set "yES".

5.3 Setup / Parameter setting

Push P key for 3 s to enter setup and "SEtUP" is displayed.

Push ↑ key to enter MENU 1 (parameters)

Push * key to enter MENU 2 (Hourmeter)

Push P key to access the next Parameter and Parameter setting.

Push P key for 3 s to exit the setup at any point.

5.3.1 Default parameters (factory settings)

All default values are written in **BOLD** characters.
The display can be reset to default parameters with the following procedure:

- take out battery and wait for 10 s.
- while putting in the battery push * key ("dEFPAr" is displayed)

5.3.2 Parameter list MENU E 1

Unit Measurement unit [dEC, FrEE, dG1, dG2, IdEC, lfrct]

Sets the measurement unit and the display mode.

dEC = linear measurement display (decimal)

FrEE = display with conversion factor

dG1 = angular display (-∞..-0,1°..0,0°..+0,1°..+∞)

dG2 = angular display (..359,9°..0,0°..359,9°..0,0°..)

IdEC = inch display mode

lfrct = fractional inch mode (eg. 12.31.64 = 12" ³¹/₆₄)

* = save, **P** = next parameter, **P** for 3 s. = exit

COn only with Unit = FrEE, dG1, dG2

[0.00001, 9.99999]

Allows to set a free conversion factor to display non-metric units or angles.

Default value: 1.00000

Example 1:

Want to display a 90° angle (from 0° to 90°) with 0,1° resolution on a round table with 785,4 mm circumference.

The measurement length on 360° is 785,4 mm, though on 90.0° it is 785,4 / 4 = 196.35.

COn = 900 : 19635 = 0,045836

Example 2:

Want to display angles on a magnetic ring with diameter 114,5 mm.

The circumference is 114.5 * 3.14 = 359.53 mm

COn = 3600 : 35953 = 0,10013

* = save, **P** = next parameter, **P** for 3 s. = exit

rES Resolution

(only with Unit = dEC, FrEE, dG1, dG2, IdEC)

Sets the resolution to be displayed.

Unit = dEC, FrEE, dG1, dG2 = 0.01, 0.05, **0.1**, 0.5, 1

Unit = IdEC = 0.001, 0.005, **0.01**, 0.05, 0.1

* = save, **P** = next parameter, **P** for 3 s. = exit

dIrr Counting direction [uP, dn]

uP = up (standard direction)

dn = down (inverted direction)

* = save, **P** = next parameter, **P** for 3 s. = exit

5.3.3 Additional function of MENU E 1

F_mml mm/inch function [yES, no]

Enables the mm/inch function (by pushing ← key)

yES = enabled

no = disabled

* = save, **P** = next parameter, **P** for 3 s. = exit

F_rEL Incremental measurement function [yES, no]

Enables incremental measurement function (by pushing **P** and * keys).

yES = enabled

no = disabled

* = save, **P** = next parameter, **P** for 3 s. = exit

F_rSt Datum function [yES, no]

Enables datum function (by pushing * key).

yES = enabled

no = disabled

* = save, **P** = next parameter, **P** for 3 s. = exit

F_rEF Datum modification function [yES, no]

Enables reference modification function (by pushing **P** and ↑ key).

yES = enabled

no = disabled

* = save, **P** = next parameter, **P** for 3 s. = exit

F_oFS Offset modification function [yES, no]

Enables offset modification function (by pushing **P** and ← keys).

yES = enabled

no = disabled

* = save, **P** = next parameter, **P** for 3 s. = exit

rEF Datum value [-999999, 999999]

Absolute reference value for the measuring system.

This value is displayed by pushing * key for 3 s. (displayed value includes previously set offset values).

* = save, **P** = next parameter, **P** for 3 s. = exit

OFSt1 Offset1 value [-999999, 999999]

First offset value (e.g. tool correction). This value is added to actual value (see 6.2.3.)

* = save, **P** = next parameter, **P** for 3 s. = exit

OFSt2 Offset2 value [-999999, 999999]

Second Offset value. This value is added to actual value and OFSt1.

* = save, **P** = next parameter, **P** for 3 s. = exit

OFSt3 Offset3 value [-999999, 999999]

Third Offset value. This value is added to actual value, OFST1 and OFST2.

* = save, **P** = next parameter, **P** for 3 s. = exit

When the setup is completed the display shows "rESEt"

Push * to reset the display and quit the setup.

Push **P** key quit the setup without resetting the display. "no rSt" will be displayed.

5.3.4 Parameter list MENUE 2

Ad xx

Function not used

* = save, **P** = next parameter

H_cntr Hour meter (1/10 h)

Elapsed time indication (display connected to battery). Resolution is 1/10 hour (6 minutes).

* = save, **P** = next parameter

6 - Cut-out

6.1 LD111

Check details on product catalogue.

6.2 LD112

Provide a 68 x 45 mm (w x h) cut-out.

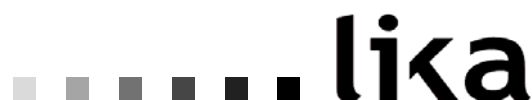

LIKA Electronic

Via S. Lorenzo, 25 - 36010 Carrè (VI) - Italy

Tel. +39 0445 382814

Fax +39 0445 382797

Italy: eMail info@lika.it - www.lika.it

World: eMail info@lika.biz - www.lika.biz